

1 STRINGER(s) MARK: 16S1
 >>> PER SPEC'S <<<

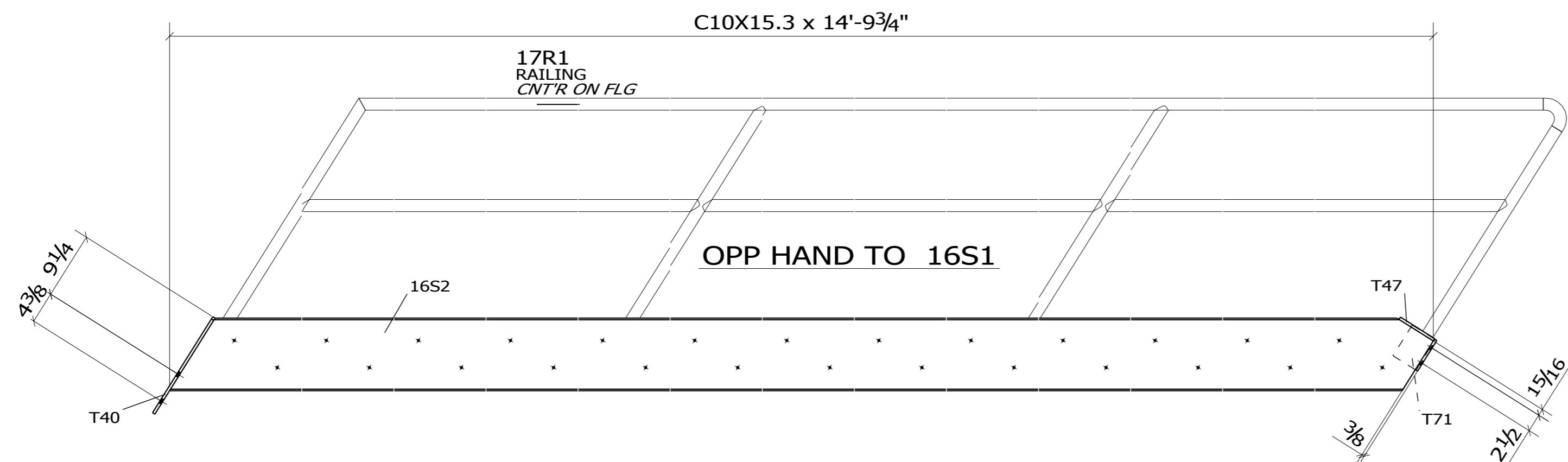

1 STRINGER(s) MARK: 16S2
 >>> PER SPEC'S <<<

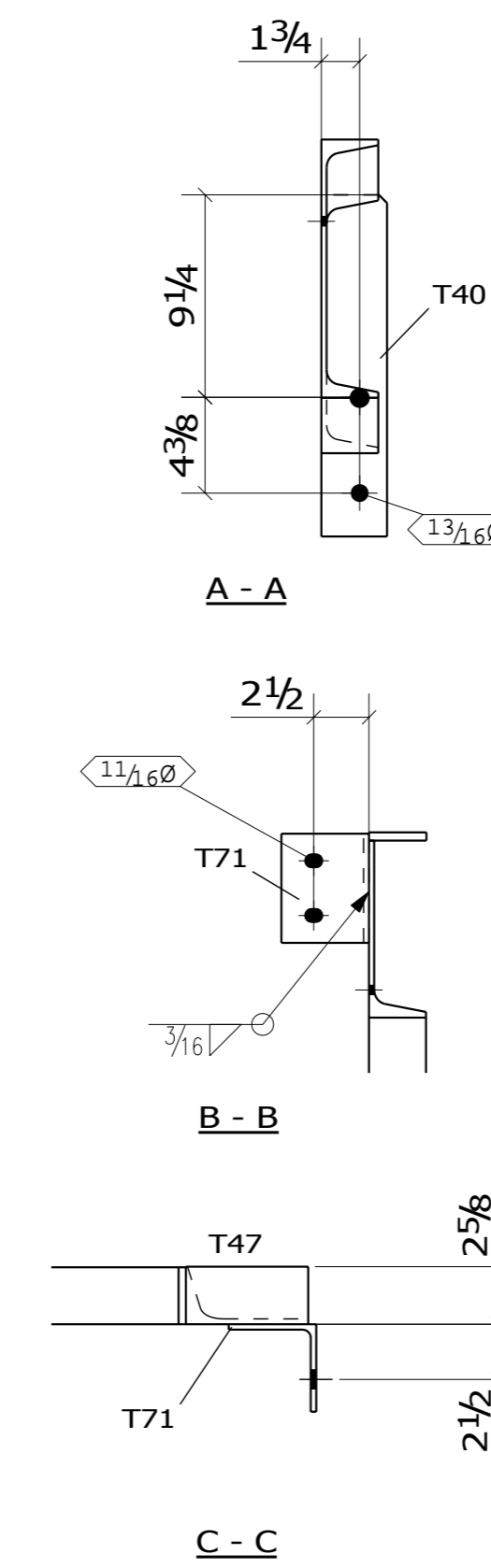

BILL OF MATERIAL									
ABM MARK	SHIPPING MARK	ASSY MARK	NO. REQ'D	DESCRIPTION	LENGTH	GRADE	WEIGHT	REMARKS	
16S1			1	STRINGER					
			16S1	1	C10X15.3	14'-9 3/4"	A36	226	STRINGER
			T40	1	PL3/8X3	1'-3 5/8"	A36	5	
			T47	1	PL3/8X2 5/8	0'-5 9/16"	A36	2	
			T71	1	L4X4X1/4	0'-5"	A36	3	
16S2			1	STRINGER					
			16S2	1	C10X15.3	14'-9 3/4"	A36	226	STRINGER
			T40	1	PL3/8X3	1'-3 5/8"	A36	5	
			T47	1	PL3/8X2 5/8	0'-5 9/16"	A36	2	
			T71	1	L4X4X1/4	0'-5"	A36	3	
							TOTAL =	471	

1-25-10		ISSUED FOR APPROVAL & FABRICATION			
MATERIAL: A36	BOLT: A325	HOLE SIZE: U.O.N.	NOTED	WELD: 3/16"	ELECTRODE: E70xx
FABRICATORS LOGO			Theman, Inc.		
STREET ADDRESS		PHONE: (555) 123-4567		E70xx	
CITY, ST ZIP		FAX: (555) 123-4567		Professional Steel Detailing & Consulting	
ARCH: PUBLIC WORKS FORT WAINWRIGHT	ENGR:		JOB NAME & LOCATION: RANGE TOWER FT. WAINWRIGHT, AK		
CONTR:	REF:		JOB: 10-0102		
DRAWN BY: TMI 01/24/2010		CHECKED BY: JP 1-24-10		SHEET: 16	
SHEET TITLE: STAIRS					