

BILL OF MATERIAL									
APR. MARK	SHIPPING MARK	ASSY MARK	NO. REQ'D	DESCRIPTION	LENGTH	GRADE	WEIGHT	REMARKS	
56B1			1	RIDGE					
	56B1		1	W27X129	51'-2 3/8"	A992	6586		
	T19		4	PL3/8X6	0'-10"	A36	26		
	T42		2	PL1/2X4 1/2	1'-0"	A36	15		
	T67		20	PL1/4X10	1'-3 11/16"	A36	221		
	T71		1	PL5/8X10	6'-11 7/16"	A36	141	SLOT	
	T72		1	PL5/8X10	13'-8 5/16"	A36	284	SLOT	
	T80		40	PL1/4X12 11/16	1'-7 5/16"	A36	439	SHAPE	
	T156		4	PL1/2X4 1/2	1'-0"	A36	31		
	T162		2	BPL3/8X11 3/16	1'-4"	A36	38	BRAKE	
	T172		1	BPL3/8X11 13/16	1'-4"	A36	27	FROM	
	TROD9		6	1" ALL THREAD	1'-0 3/8"	A36	16	BC1E	
	TWS40		20	5/8" Ø TWS	0'-5 1/2"	A108	10		
	TWS45		30	5/8" Ø TWS	0'-2 1/2"	A108	7		
							TOTAL =	7838	

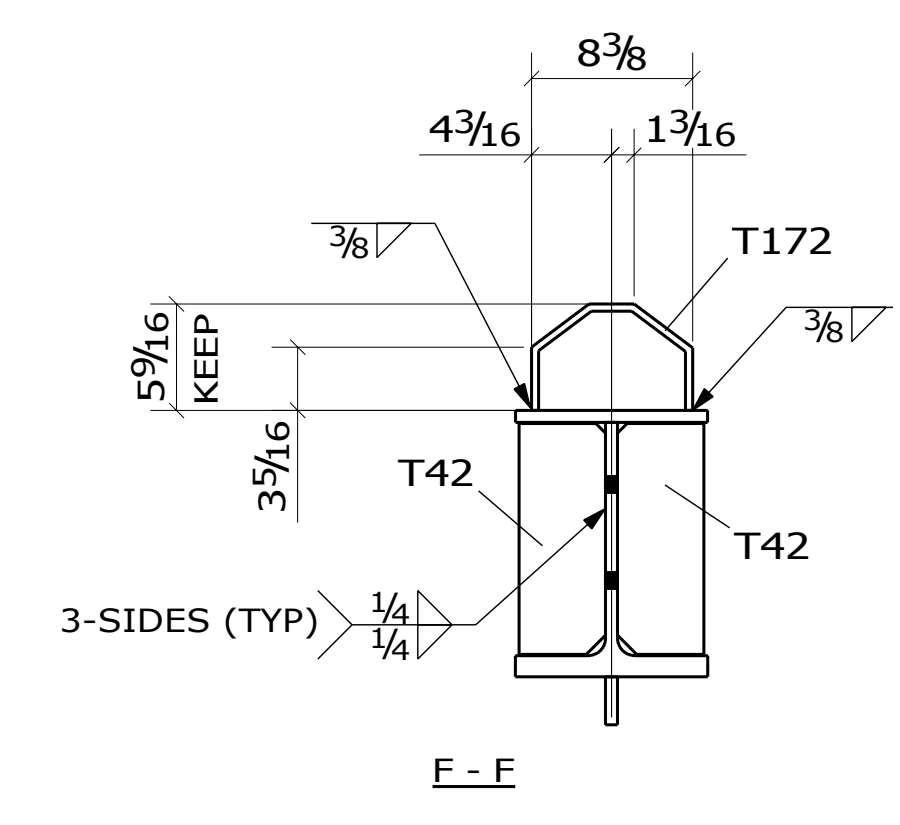
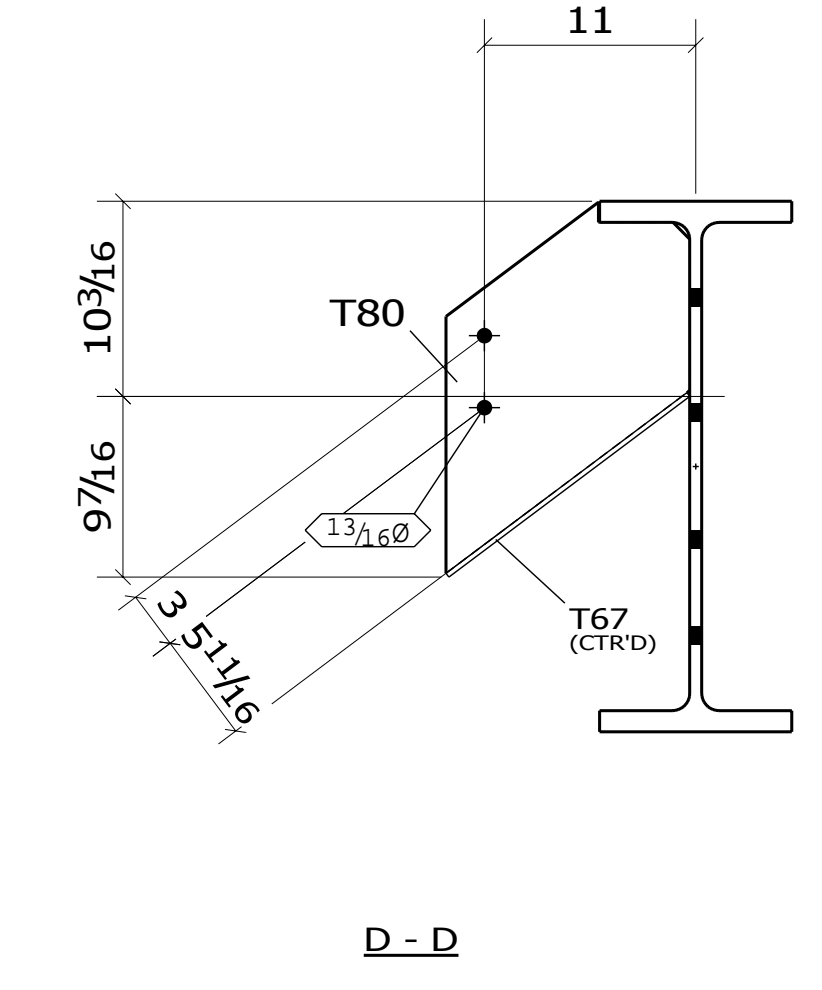
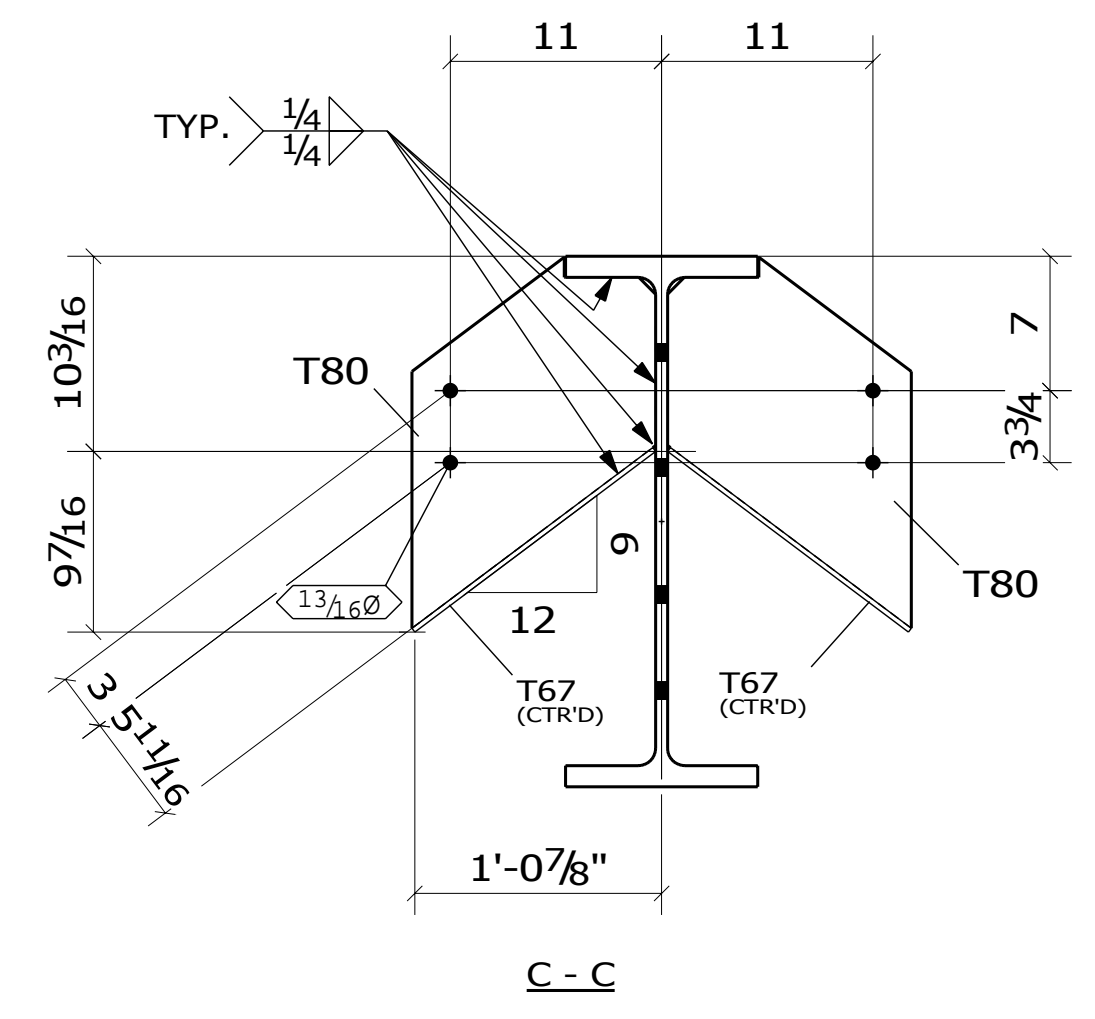
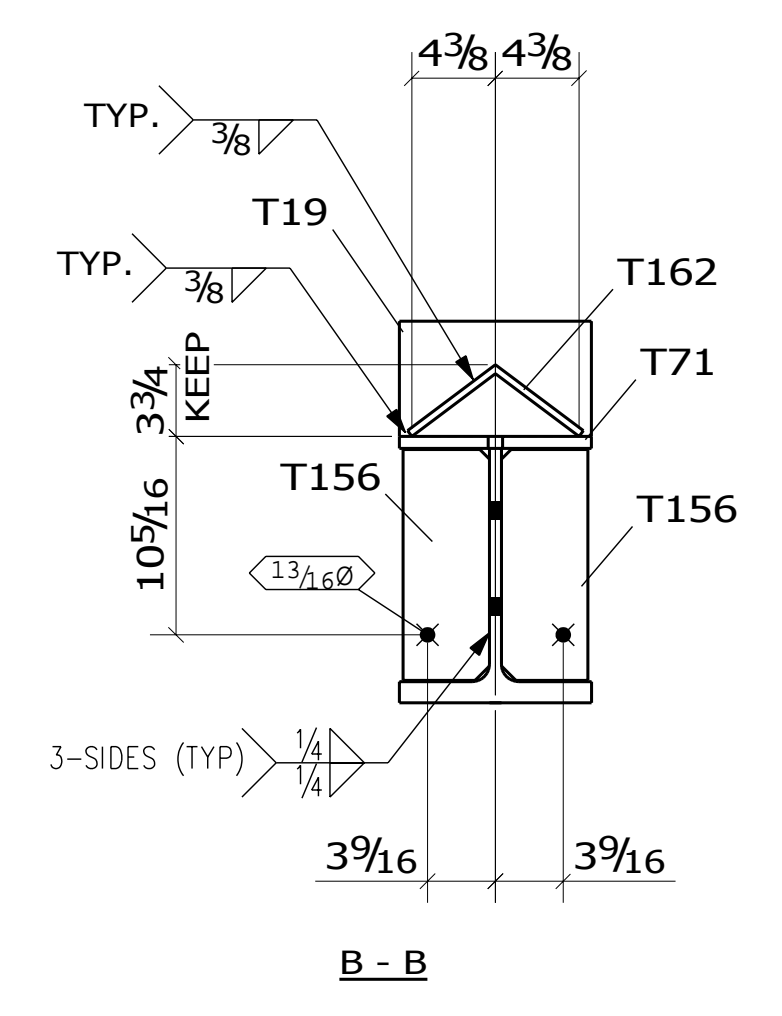
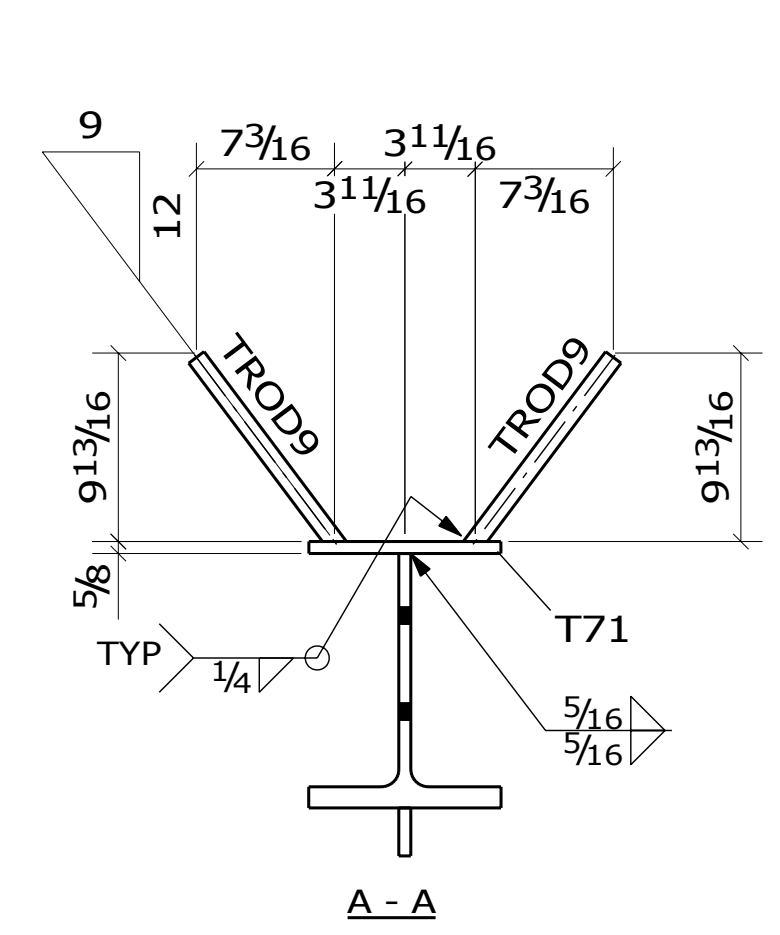
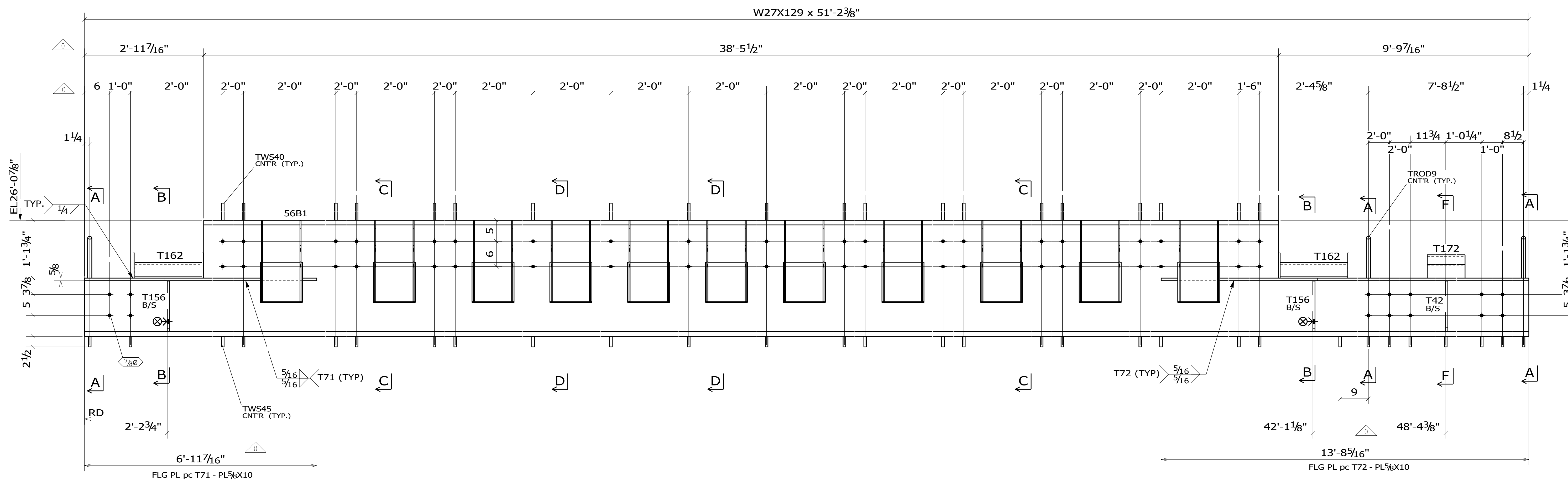
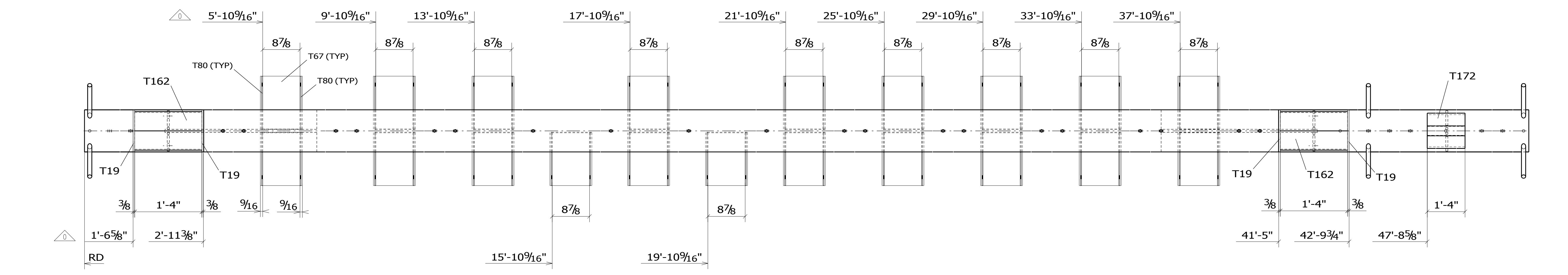

1 RIDGE(S) MARK: 56B1
 >>> SHOP PRIME <<<
 (REF: E/S6.1)

9-20-11 ISSUED FOR FABRICATION - REVISED PER APPROVAL
 9-1-11 ISSUED FOR APPROVAL

MATERIAL: A992 U.O. BOLT: A325 U.O. HOLE SIZE: 13/16" U.O.N. WELD: ELECTRODE:

FABRICATORS LOGO

STREET ADDRESS: PHONE: (555) 123-4567
 CITY, ST ZIP: FAX: (555) 123-4567

ARCH: Architects, Inc. San Diego, CA
 ENGR: Engineers, Inc. San Bernardino, CA
 CONTR: Contractors, Inc. La Brea, CA

JOB NAME/LOCATION: Mountain Residence, Joyland, CA

REF: DRAWN BY: TMI 08/30/2011 CHECKED BY: JP 8-31-11 SHEET: 56/78

RIDGE BEAM - GREAT ROOM