

1st FLOOR (NORTH)- TOP OF SLAB EL. 63'-6" (U.O.N.)
 SEE E2 FOR SOUTH PORTION OF SLAB

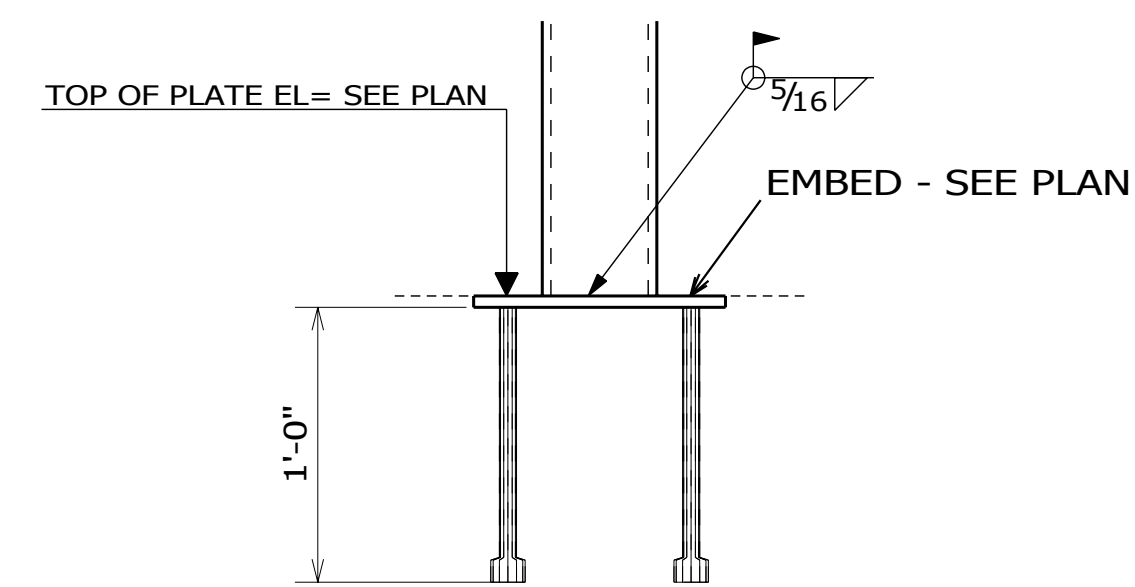

TYPICAL COLUMN BASE DETAIL

9-14-11	ISSUED FOR CONSTRUCTION	- PER APPROVAL
5-25-11	ISSUED FOR APPROVAL	
FABRICATORS LOGO		
STREET ADDRESS		PHONE: (555) 123-4567
CITY, ST ZIP		FAX: (555) 123-4567
Thorburn, Inc. Phone: 760-295-1860 Fax: 760-269-3135 Professional Steel Detailing & Consulting		
ARCHITECT	DESIGNER	CONTRACTOR
ENGINEER	CONTRACTOR	
JOB NAME & LOCATION La Jolla Condo La Jolla, CA		
REF:	CHECKED BY: JP	JOB: 1234
DRAWN BY: TMI	DATE: 05/23/2011	SHEET: E1
SHEET TITLE KEY PLAN		